

Pillars Stage Left and Right - view from audience right
upstage

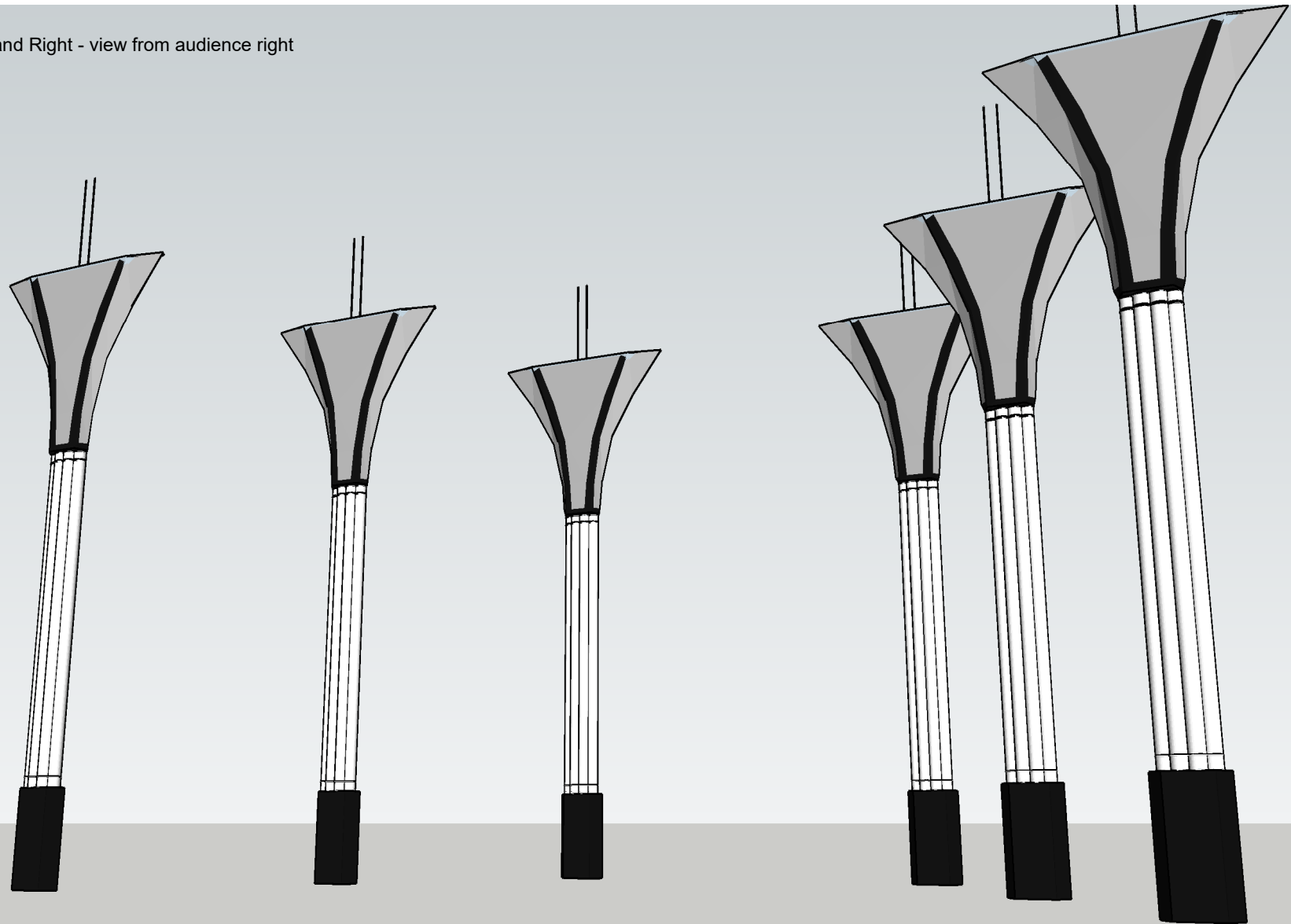

CLIENT
Salos

PROJECT
Sound of Music

PROJECT NO.
0111.19

DRAWN BY
Jacob Corn

DESCRIPTION
Pillar Detail - Mid Section

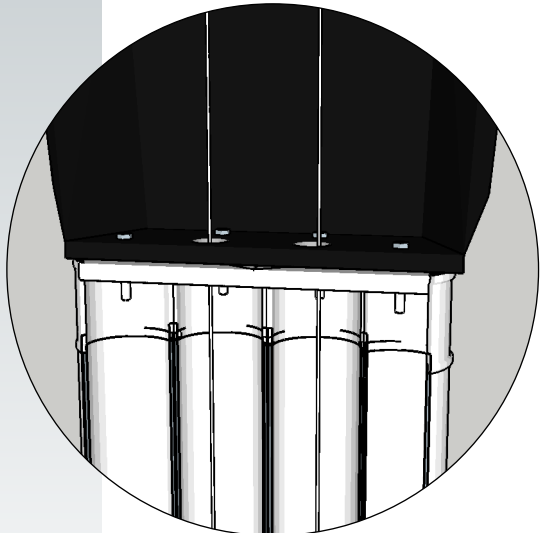
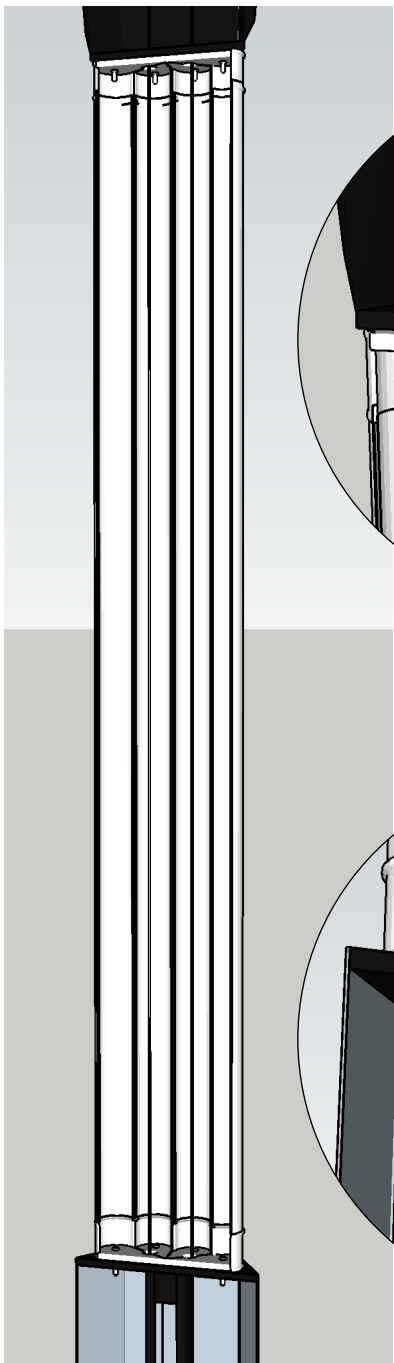
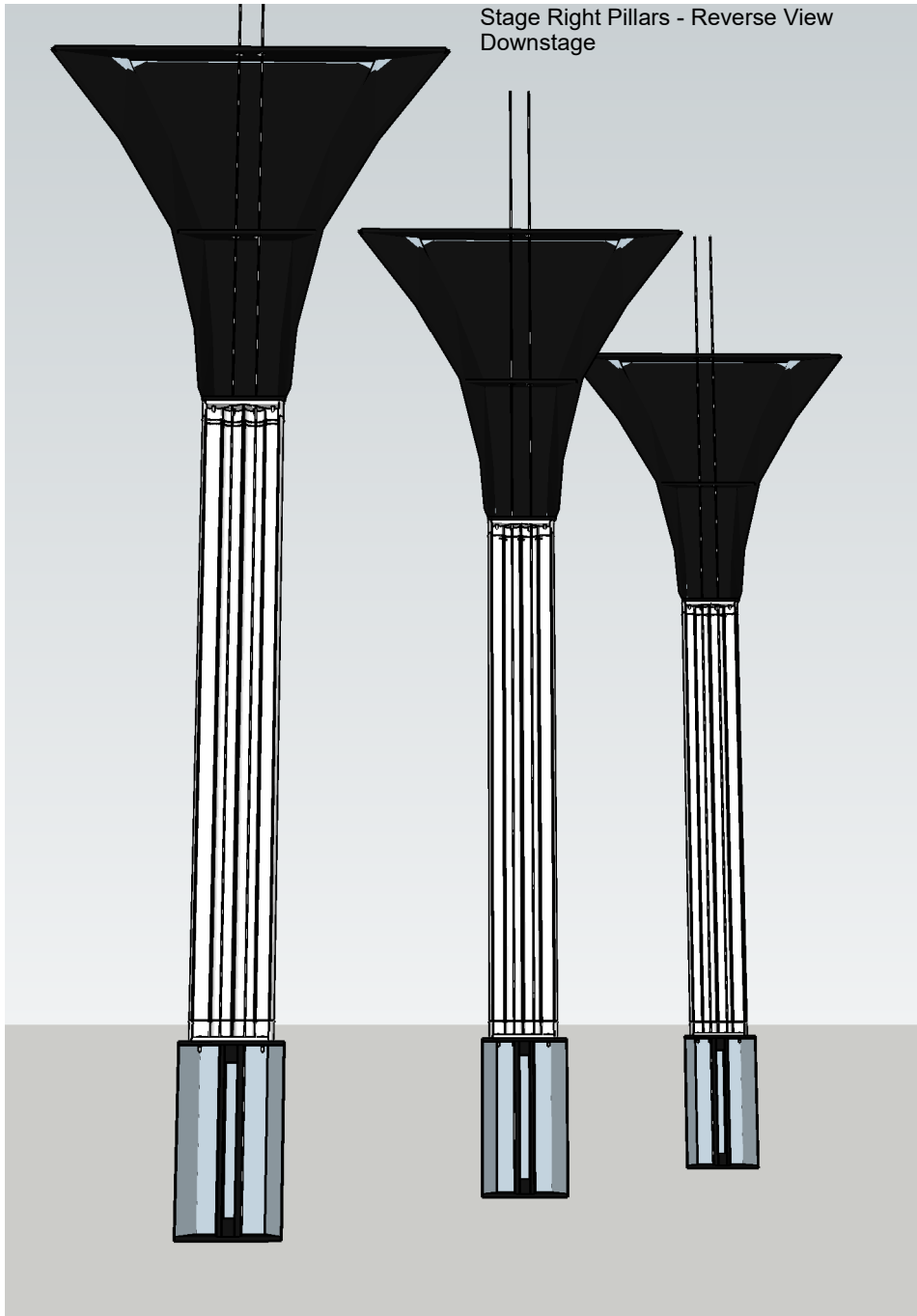

Connection Detail - Rigging Irons x2
and M10 Bolts x4 through both top
and Mid Section

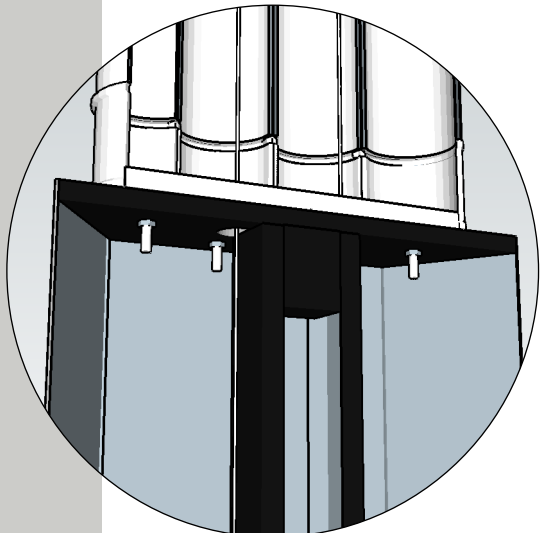

Connection Detail - Rigging Irons x2
and M10 Bolts x4 through both Mid
and Base Section

| | | | | |
|---|--|------------------------|----------|----|
| CLIENT Salos Theatre, The Wyvern Theatre Swindon | PROJECT NO. 0111.19 Sound of Music Columns - Mid - Detail | DRAWN BY Jacob Corn | a | 01 |
|---|--|------------------------|----------|----|

Pillar Mid Section
reverse view

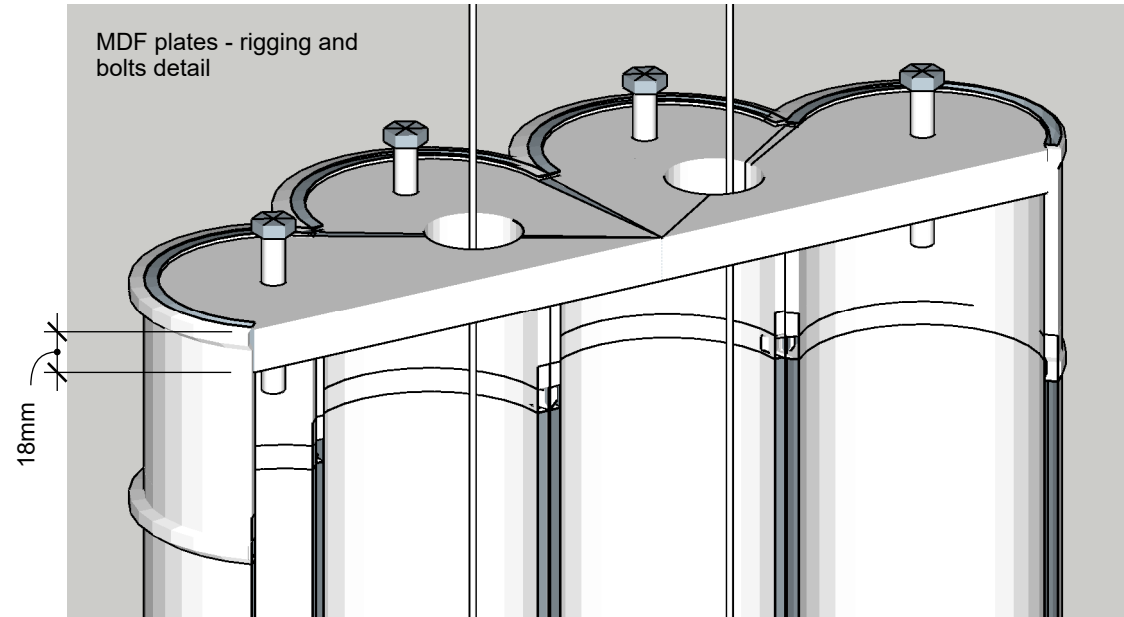
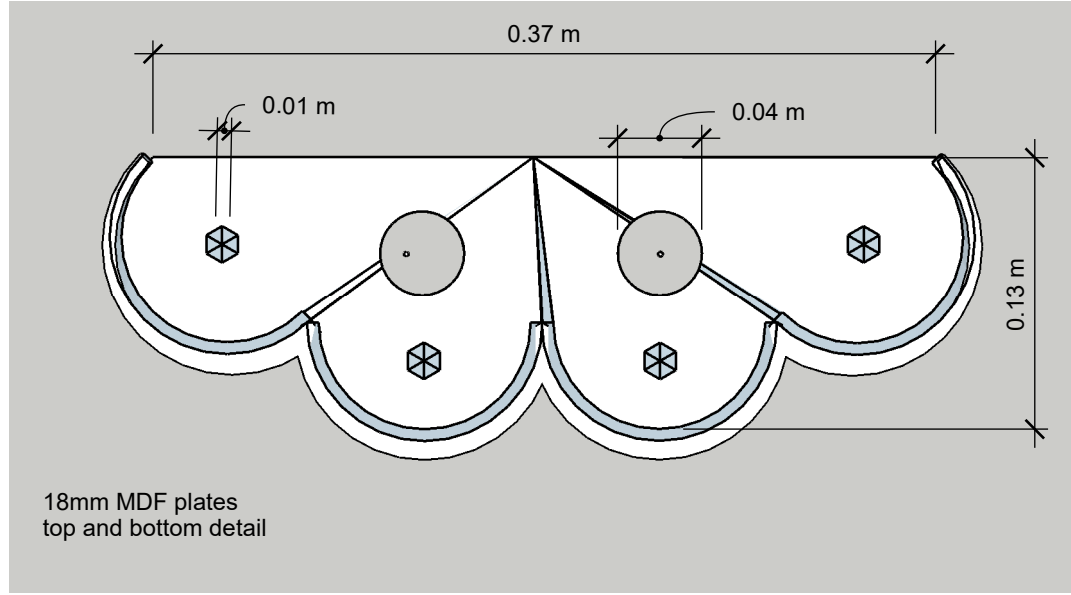
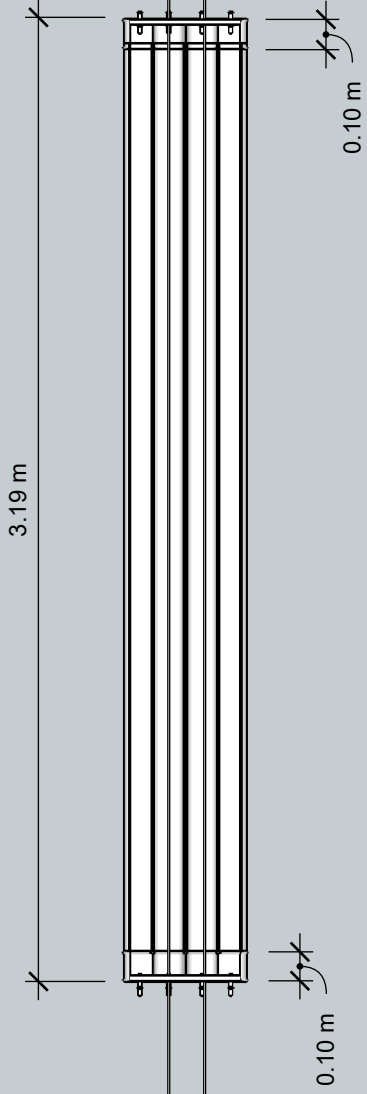

CLIENT
Salos Theatre,
The Wyvern Theatre
Swindon

PROJECT NO.
0111.19
Sound of Music
Columns - Mid - Detail

DRAWN BY
Jacob Corn

a

02